

**Installation Summary:**

The residence experiences voltage drops when large loads and especially the out doors hot-tub turn on and off. This is mainly due to under-dimensioned transformer between fuel cell and PowerTower and built-in delay in the PowerTower. The problem grew worse as the outside temperature went down as the heating element in the hot-tub would cycle more frequent. In order not to inconvenience the resident at the demonstration site, the fuel cell and the PowerTower were taken off-line and the electricity provided by the utility.

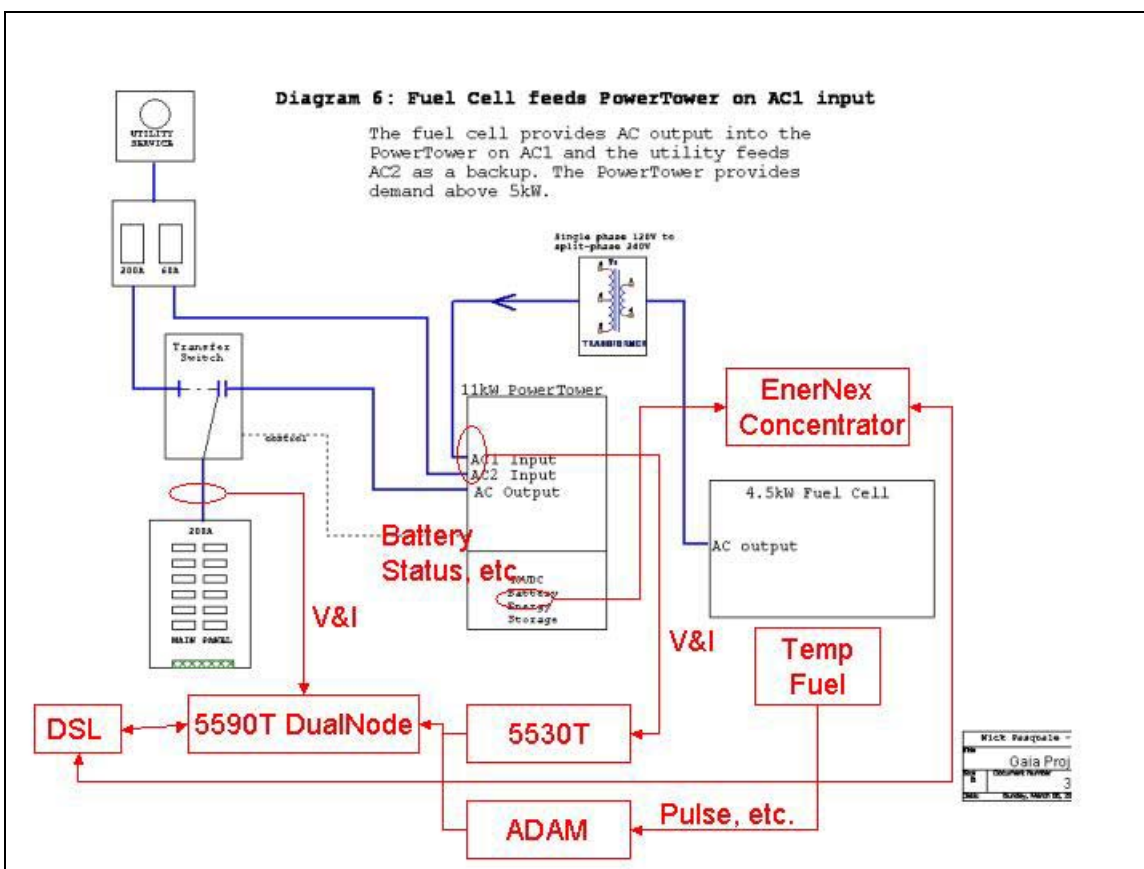
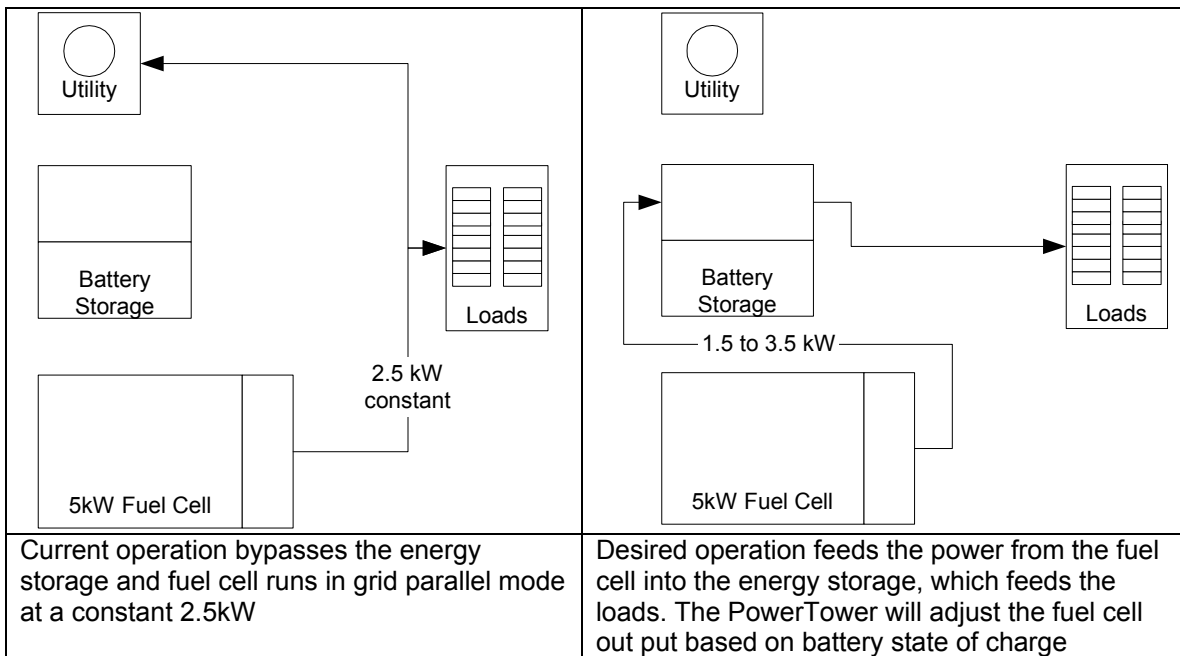

Figure 1: Comprehensive 1-line diagram for test site including data acquisition nodes

The fuel cell was subsequently turned back online January 17<sup>th</sup> and operated in grid parallel mode, supplying a constant 2.5kW to the demonstration site. In case the load in the demonstration site drops below the output of the fuel cell excess power is fed back to the grid.

We were looking to replace the transformer with an auto-transformer, which can keep the voltage steady on the input side but it was found technically and economically unfeasible. Instead it has been decided to remove the hot-tub as a load. This will happen on February 14<sup>th</sup>. At the same time the satellite dish will be realigned in order to reestablish real time data acquisition. This will

allow us to report on both system performance and to initiate a test matrix optimizing the fuel cell output power with the depth of discharge of the battery storage.



**Figure 2: Simple 1-line diagram illustrating current and desired operation.**